

living & co.

4 Tier Metal Wire Rack

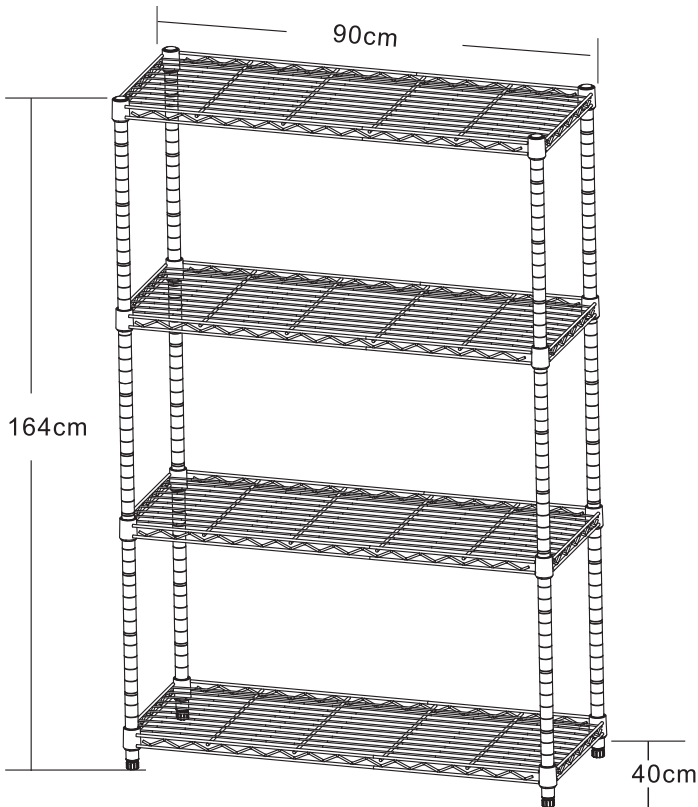

INSTRUCTION MANUAL

Maximum weight: 30 kgs per shelf

AFTER SALES SUPPORT

☎ (NZ) 0800 422 274

Important Safety Instructions

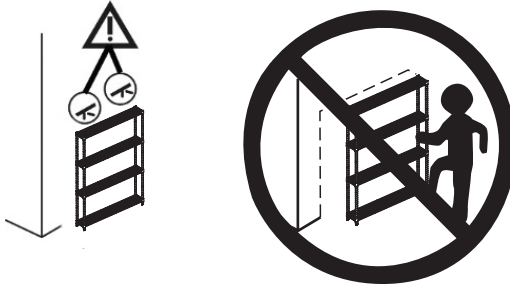

⚠️ WARNING:

Serious or fatal crushing injuries can occur from furniture tip-over. Use of tip-over restraints may only reduce but not eliminate the risk of tip-over. To help prevent tip-over:

- Place heaviest items in the bottom shelves.
- Unless specifically designed to accommodate, do not set TVs or other heavy objects on top of this product.
- Never allow children to climb or hang on the shelves.

Assembly Details

10 mins

Approximate Assembly Time



2 person assembly

Floor Area:

2x2 meters

Required Assembly Space

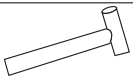

Rubber Mallet

AFTER SALES SUPPORT

☎️ (NZ) 0800 422 274

Tips Before you Start

1. Please check that all parts are present before you start the assembly of your furniture.
2. For ease and speed of assembly, we recommend that before you commence each step of the assembly, that you identify all the parts required for that step.
3. For larger items, please ensure that you have sufficient space and people (as indicated on page 1) to assemble your product safely.
4. We recommend that, where possible, all items are assembled near to the area in which they will be placed in use, to avoid moving the product unnecessarily once assembled.
5. For the protection of your furniture, we recommend that the product is placed on a protected surface during assembly to prevent any damage.
6. During assembly please take care not to over-tighten any fittings, as this may damage the product. Do not use power tools.
7. Always place the product on a flat, steady and stable surface.
8. Do not stand on the product. Do not use the product as a stepladder.
9. This product is intended for indoor, household use only as it is a non-industrial product.
10. Please use caution and care when lifting the product to avoid personal injury and/or product damage.



Care and Maintenance

- ✓ Please periodically check all fittings and re-tighten as necessary.
- ✓ Please do not use damp cloth and wipe clean the wire shelf.
- ✓ Never allow any kind of liquid to remain on your furniture.
- ✓ Absorption can cause wood to warp or finishes to de-laminate.
- ✓ Please do not place hot items (eg. hot drinks) directly on to the surface.
- ✓ Please do not drag and pull your furniture.

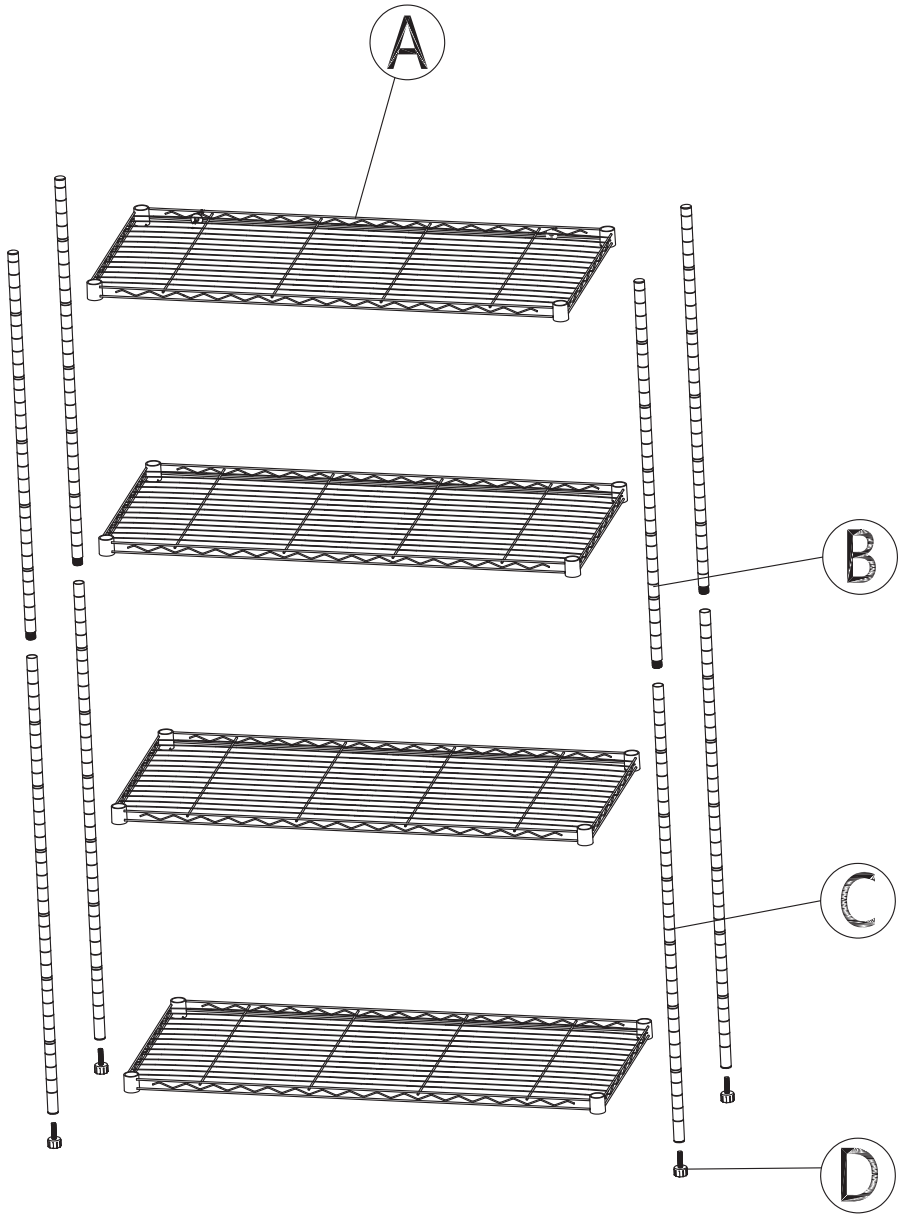
Part Name

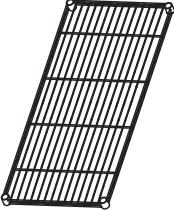
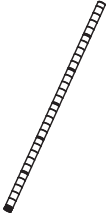
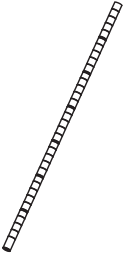
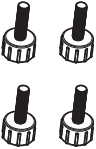

Part Name

<p>A</p>  <p>4 PCS</p>	<p>B</p>  <p>4 PCS</p>	<p>C</p>  <p>4 PCS</p>
<p>D</p>  <p>4 PCS</p>	<p>E</p>  <p>32 PCS</p>	<p>F</p>  <p>1 SET</p>

Assembly

STEP 1

Screw the Leveling Feet (D) into the bottom of four Lower Poles (C)
Snap the Plastic Clips (E) into the pole grooves of four lower poles at the same position and make sure that the arrow of plastic clips are pointing up.

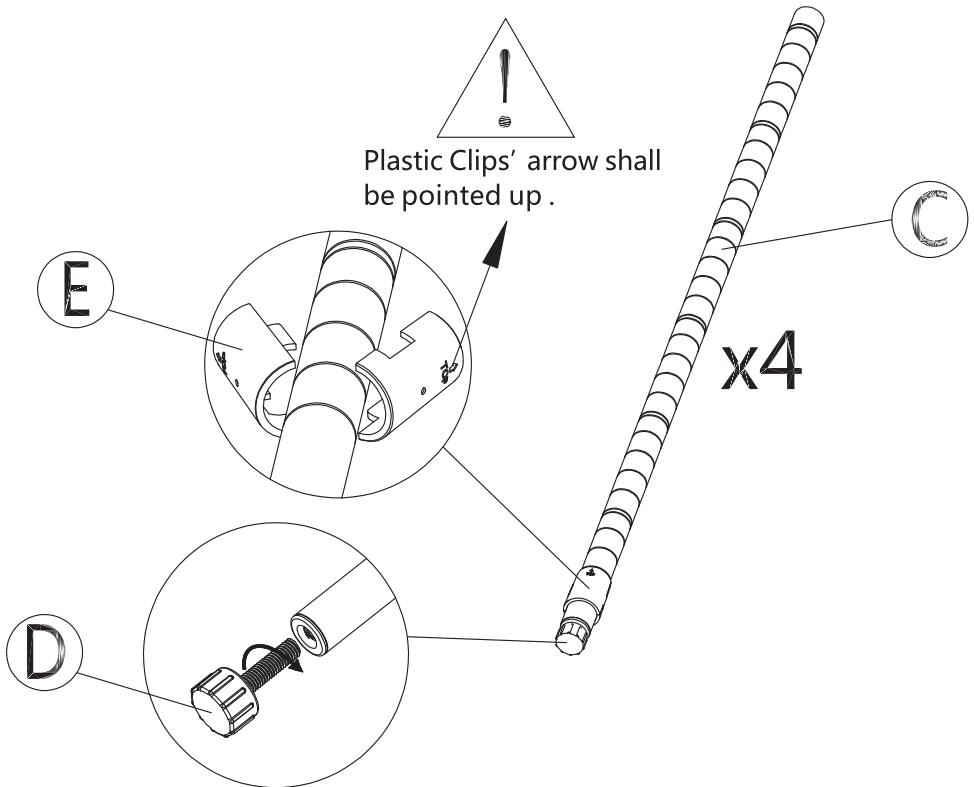

Assembly

STEP 2

Please make sure Wire Shelf (A) the correct way up. The gap in collar shall be face down) Hold the wire shelf on its side and slide the top of four lower poles through the bottom of each wire shelf at its corners until there is snug fit, After four poles have been slid through the shelf collar holes, set the shelf upright.

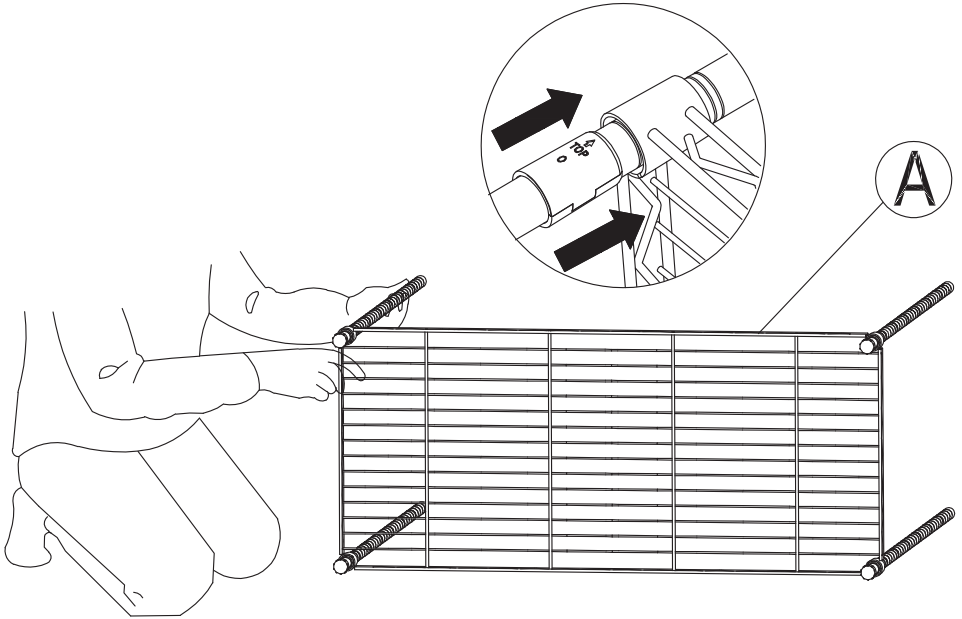

Keep the gap in collar face down

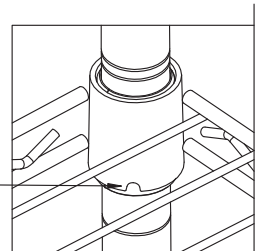

Assembly

STEP 3

Snap plastic clips into the pole grooves of the lower poles at your desired shelf height position. Slide down shelf from top onto the plastic clips.

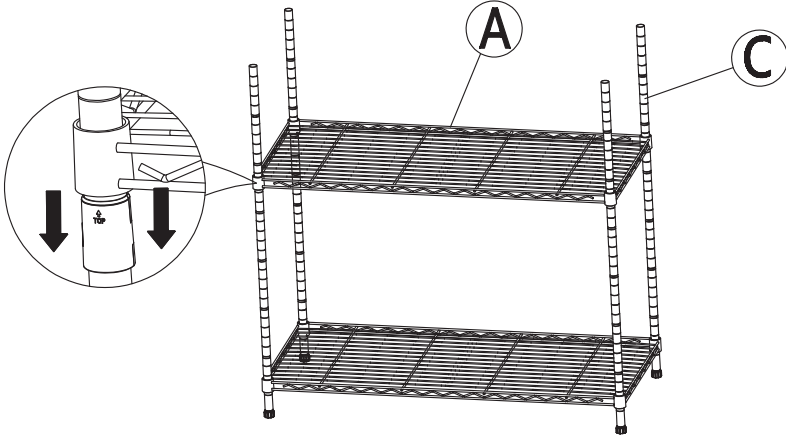

STEP 4

Screw the Upper Poles (B) into the lower poles by screw connectors which is already on the upper poles

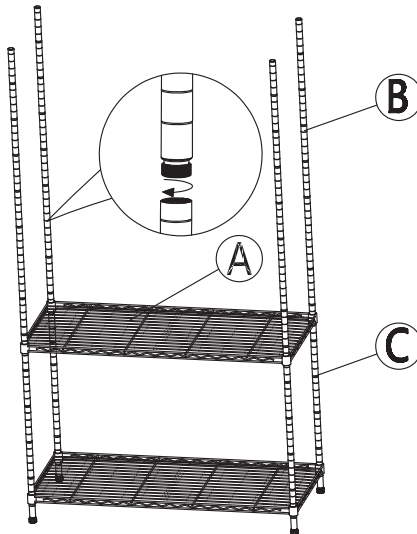

Assembly

STEP 5

Repeat the step ③ to assemble the rest of wire shelves at the place you desire

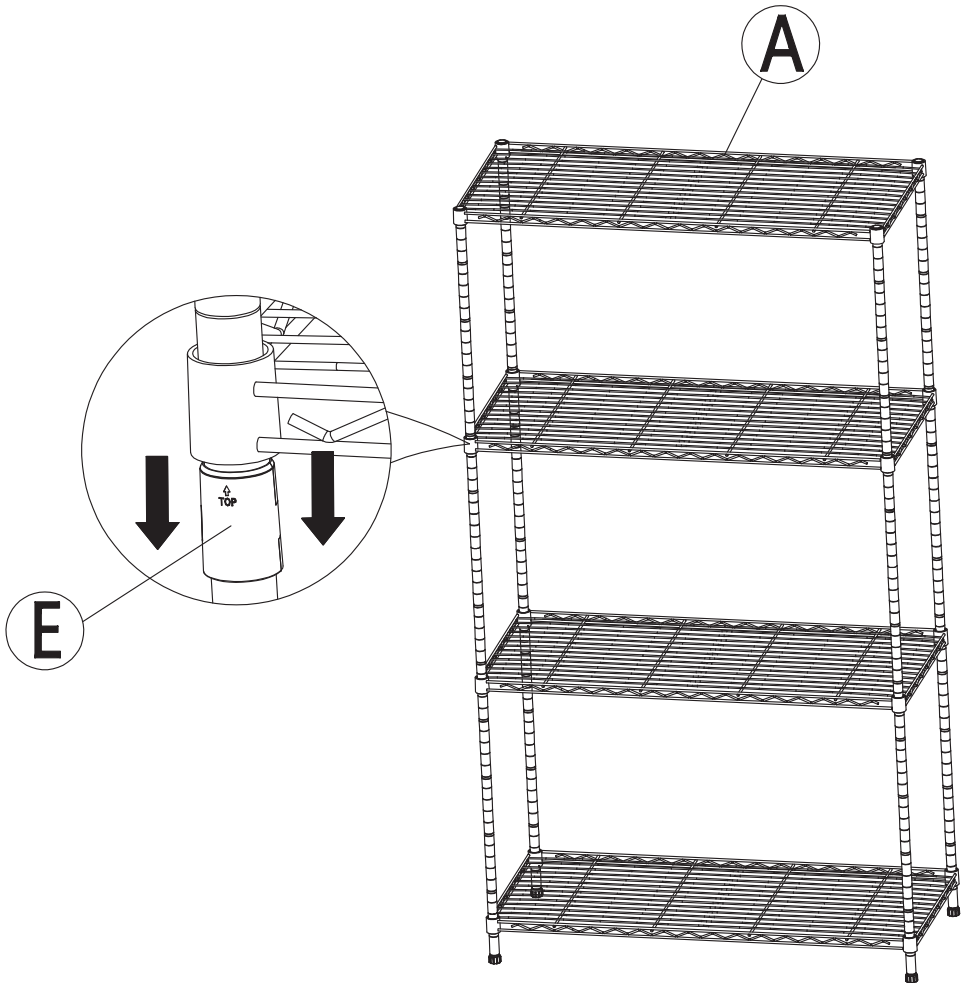

Assembly

STEP 6

Once all the wire shelves have been installed, pushing firmly down on every shelf at corners by rubber mallet to ensure the shelf in a place over the plastic clips. And screw the leveling feet in or out to attain proper leveling. Attach wire shelf as following photo to the wall by Anti-tip kits(F) to prevent rack unit from tipping over, Then wire rack is well assembled.

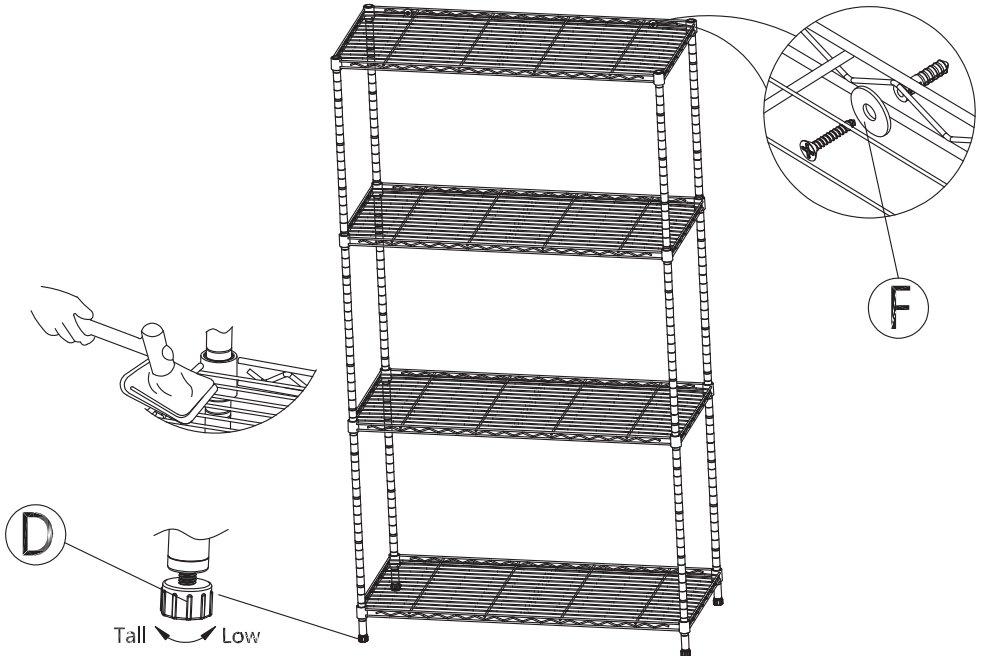



living & co.

Warranty

We pride ourselves on producing a range of quality products that are both packed with features and completely reliable. We are so confident in our products, we back them up with a one-year warranty.

Now you too can relax knowing that you are covered.

Customer Helpline NZ: 0800 422 274
This product is covered by 1 year warranty
when accompanied by proof of purchase.

AFTER SALES SUPPORT

 **NZ 0800 422 274**