



ASSEMBLY INSTRUCTIONS

WD-1002W - 9-400048-299083

CAUTION

MATERIAL USE - LAMINATED MEDIUM DENSITY FIBERBOARD AND PARTICLEBOARD FRAME
 ● TO CLEAN USE SOFT DRY CLOTH ● DO NOT USE DETERGENT OR CHEMICALS ● AVOID CONTACT WITH WATER AND DIRECT SUNLIGHT ● TO BE ASSEMBLED ON A SOFT DRY CLEAN AND SMOOTH SURFACE.

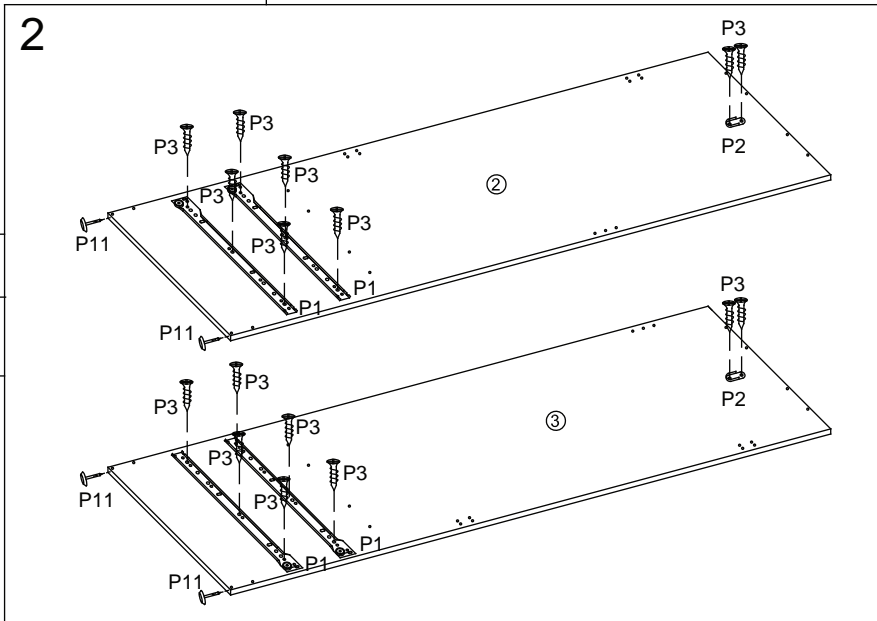
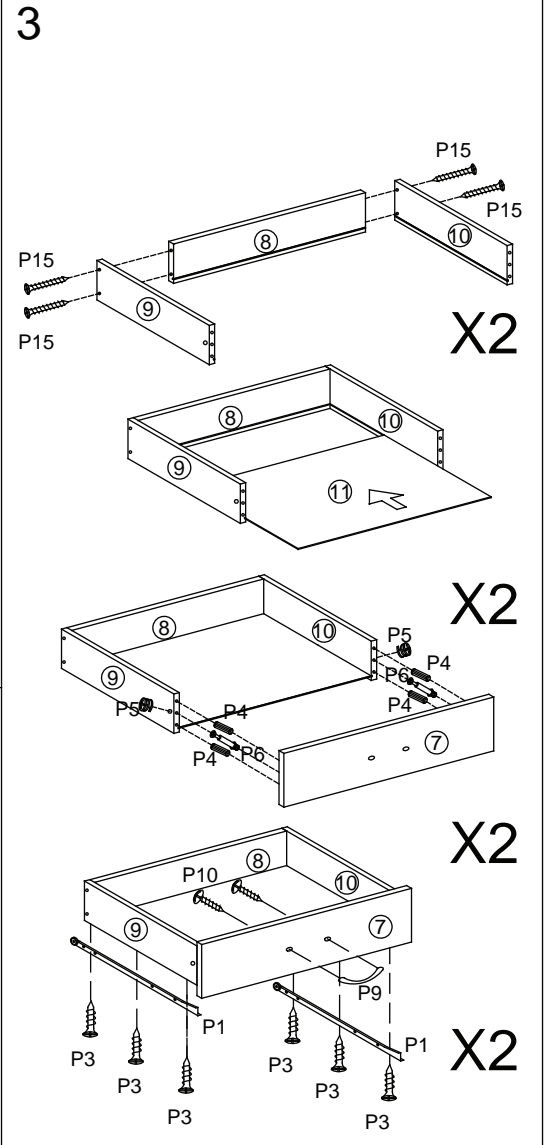
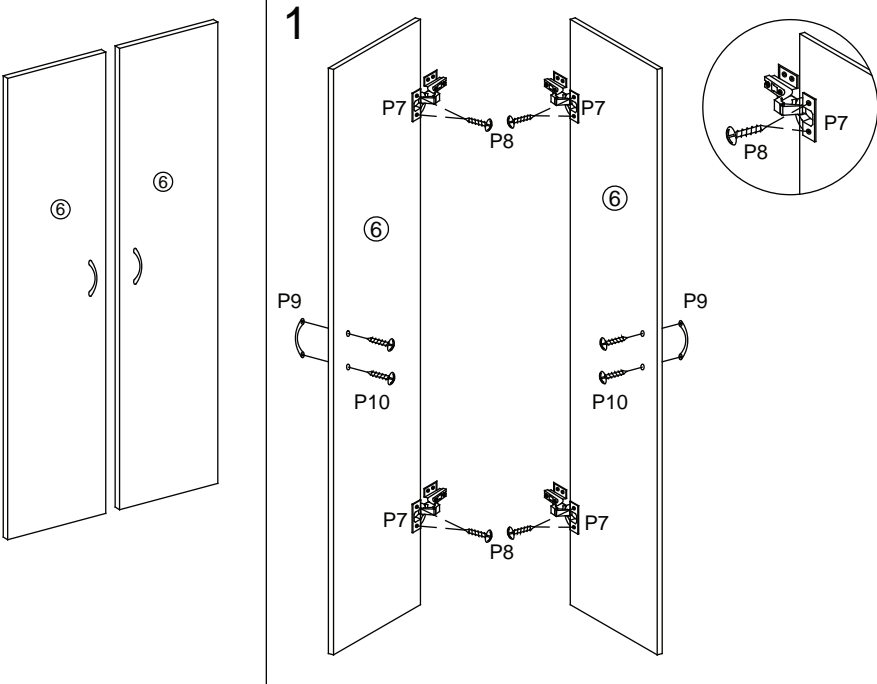
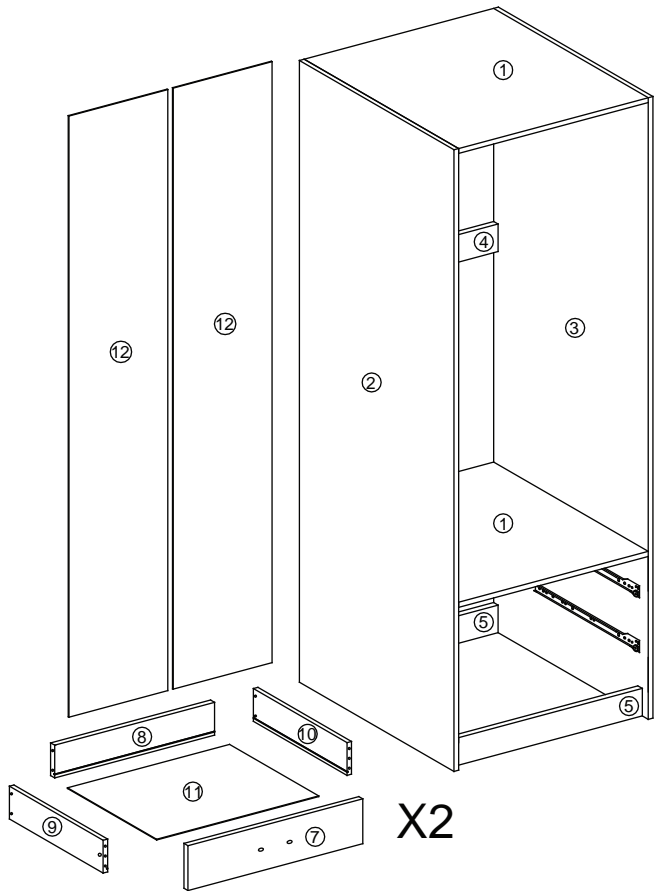

TOOLS NECESSARY

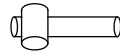
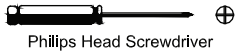

TO CORRECTLY AND SAFELY ASSEMBLE THIS PRODUCT PLEASE USE THE CORRECT SIZE PHILIPS HEAD SCREW DRIVER. PLEASE NOTE USING A POWER DRILL MAY CAUSE DAMAGE TO THE PRODUCT. DO NOT OVERTIGHTEN.

P1		2PCS	P9		4PCS
P2		2 PCS	P10		M5 X 25MM 8 PCS
P3		M3.5 X 12MM 28PCS	P11		4 PCS
P4		24PCS	P12		40 PCS
P5		18PCS	P13		1 PC
P6		18 PCS	P14		1 PC
P7		4PCS	P15		M4 X 35MM 8 PCS
P8		M4X 12MM 24PCS	P16		1 PC

4

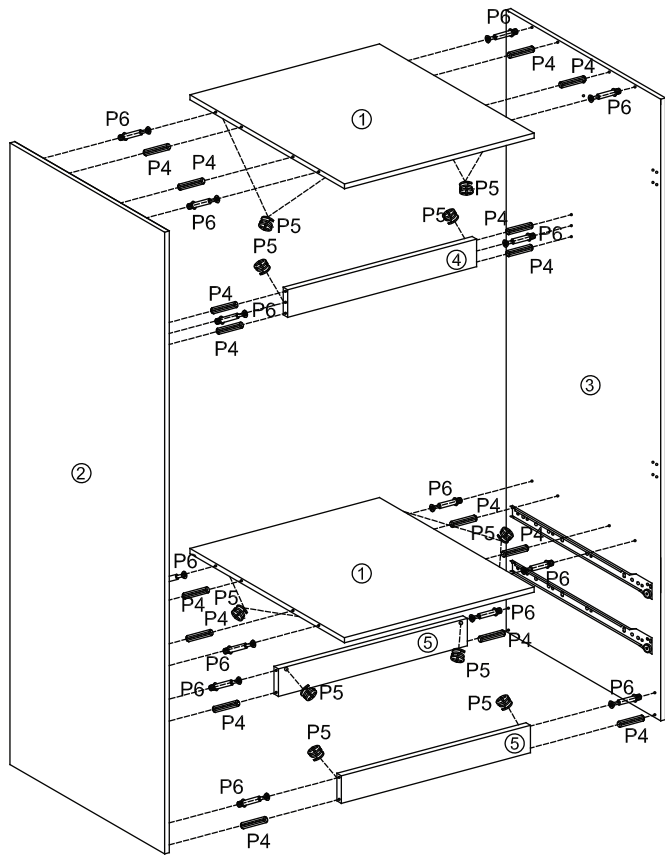

5

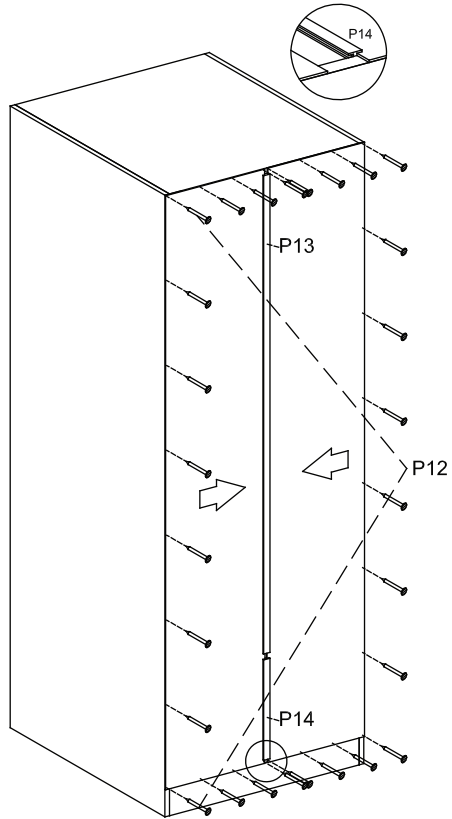

6

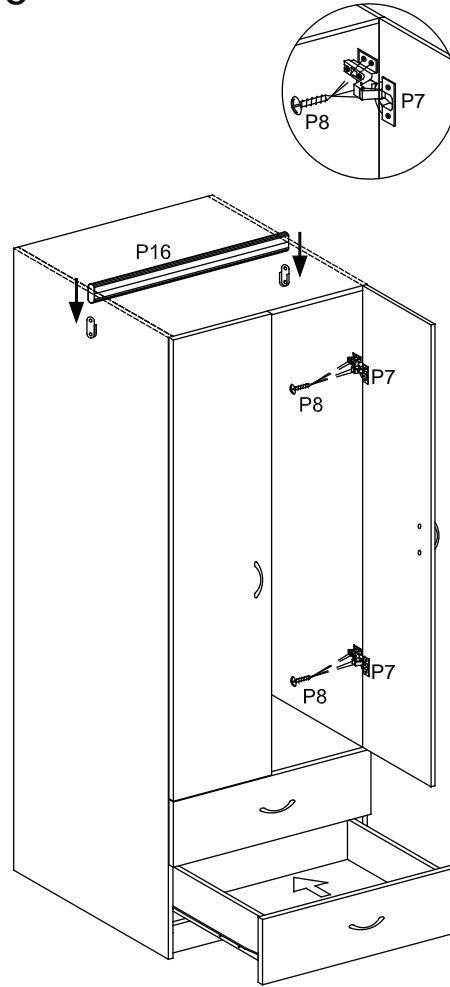

7

