

Heavy Duty Racking 3 Tier

1.0hr

APPROXIMATE ASSEMBLY TIME

2 PERSON ASSEMBLY

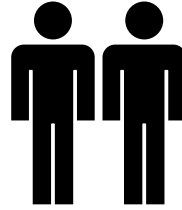

FLOOR AREA
1M x 2M

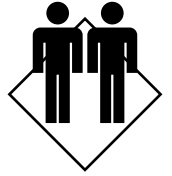

REQUIRED ASSEMBLY SPACE

ASSEMBLED DIMENSIONS

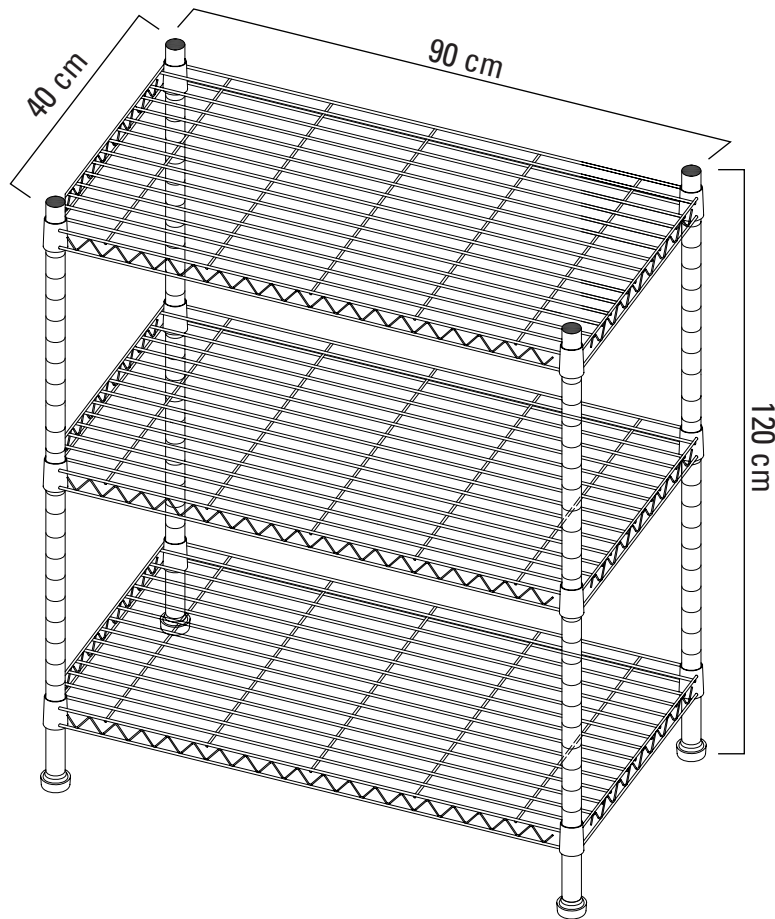

Heavy Duty Racking 3 Tier

Tips before you start:

1. Please check that all parts are present before you start the assembly of your racking.
2. For ease and speed of assembly, we recommend that before you commence each step of the assembly, that you identify all the parts required for that step.
3. For larger items, please ensure that you have sufficient space and people (as indicated on page 1) to assemble your product safely.
4. We recommend that, where possible, all items are assembled near to the area in which they will be placed in use, to avoid moving the product unnecessarily once assembled.
5. For the protection of your racking, we recommend that the product is placed on a protected surface during assembly to prevent any damage.
6. Always place the product on a flat, steady and stable surface.
7. Do not stand on the product. Do not use the product as a stepladder.
8. This product is intended for indoor, household use only as it is non industrial product.

Care and Maintenance of your Racking

- Please periodically check all fittings and brackets and re-adjust as necessary.
- To clean your item, please use a damp cloth and wipe clean.
- Please do not drag and pull your racking.

Heavy Duty Racking 3 Tier

PARTS LIST

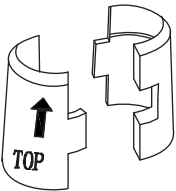

12 x A
Shelf Bracket

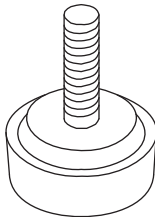

4 x B
Foot



4 x C
Upper Pole



4 x D
Lower Pole

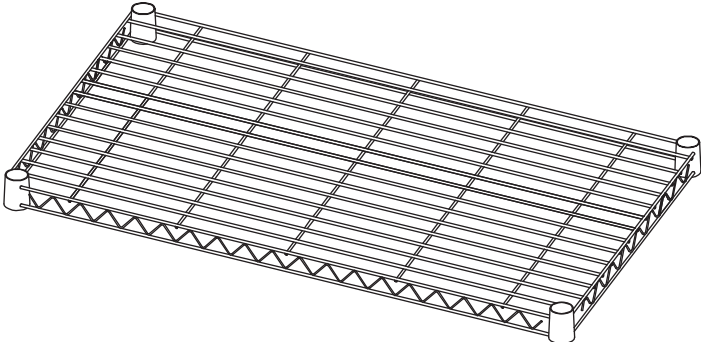

3 x E
Shelf

Heavy Duty Racking 3 Tier

STEP 1

Screw the upper (C) and lower (D) poles together.

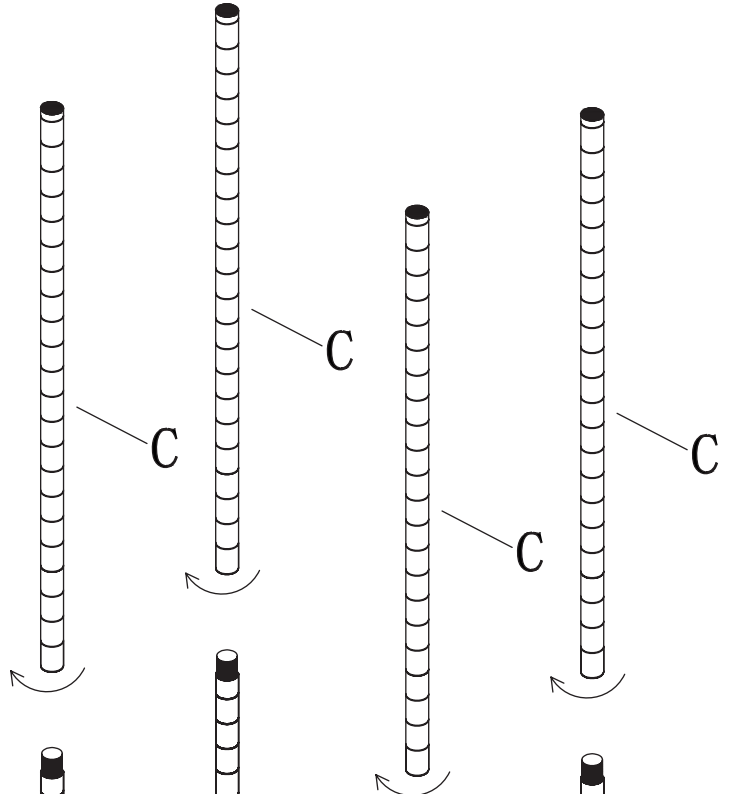

Screw feet (B) into the base of the lower poles.

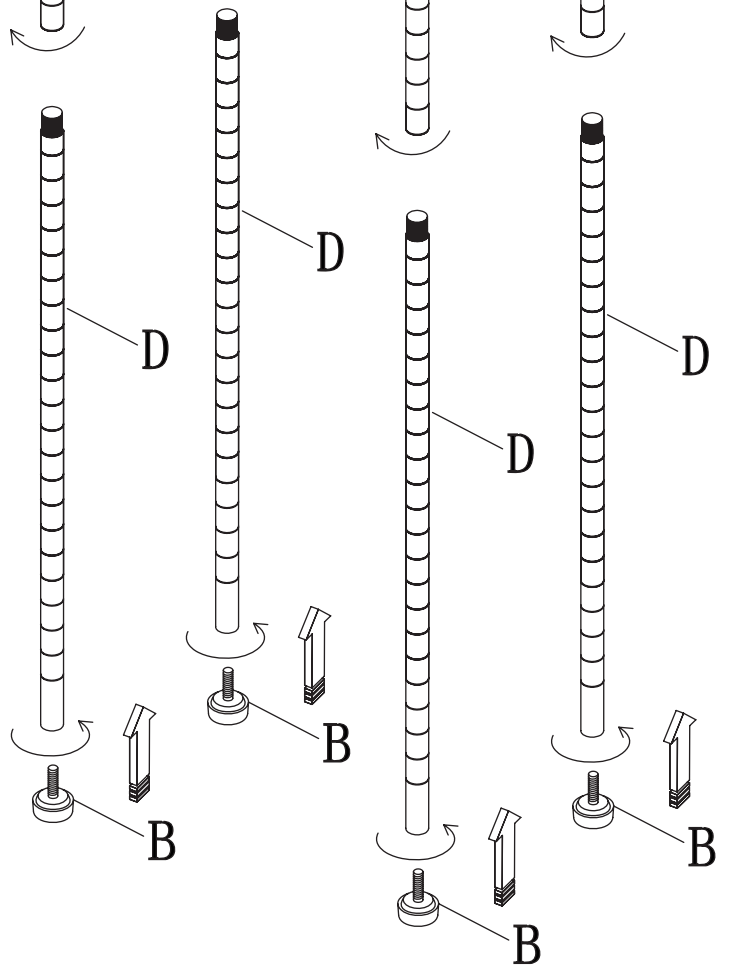

x4

Repeat this step for each of the poles.

Heavy Duty Racking 3 Tier

STEP 2

To build the shelving unit, you need to build it from the ground up.

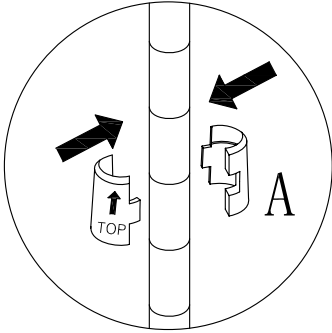

Shelving can be configured and set-up at various heights depending on your requirements.

Locate a groove along the vertical supports at the desired height to set-up a shelf.

Attach bracket (A) as shown in the diagram above.

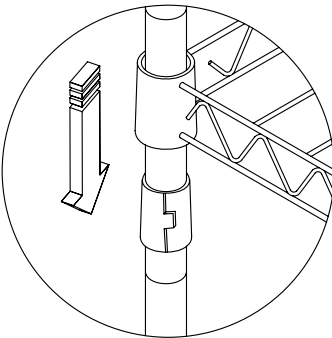

Once 4 x brackets (A) are in location on each of the 4 poles at the same level, lower a shelf (E) over the top of each of the 4 x vertical supports until the shelf is in place over the brackets.

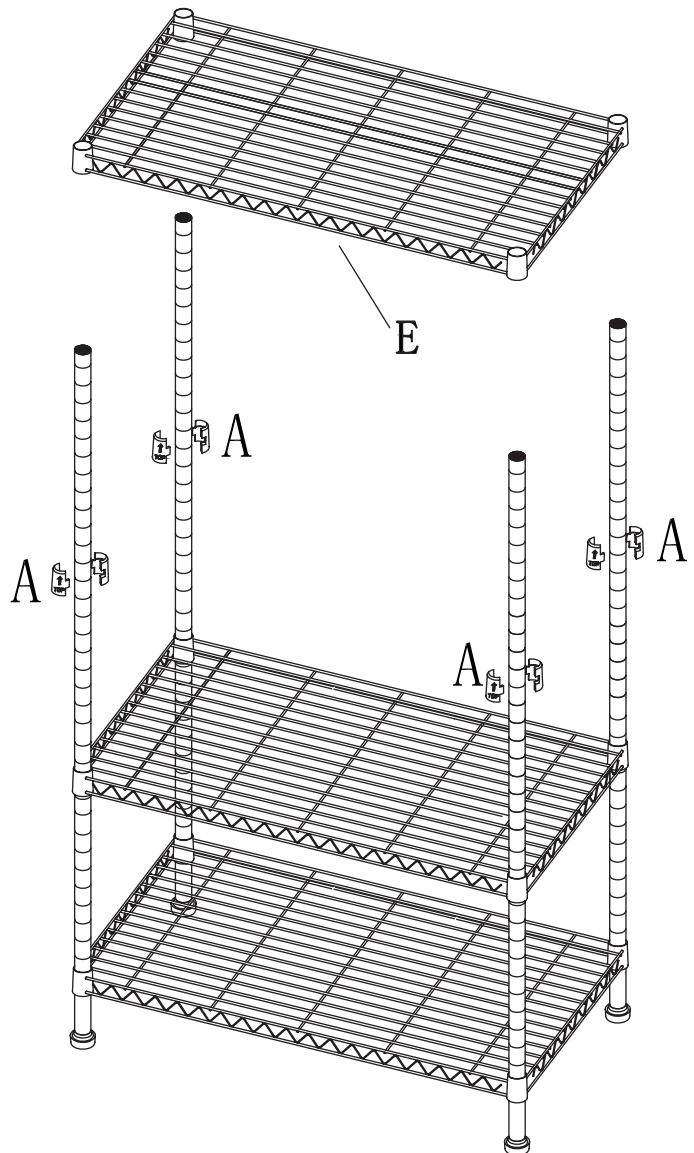

x3

Repeat this step for each of the shelves.

Heavy Duty Racking 3 Tier

STEP 3

After assembling your shelving unit, if your ground area is slightly uneven, adjust the feet (B) as needed to ensure the shelving unit is stable and safe to use.

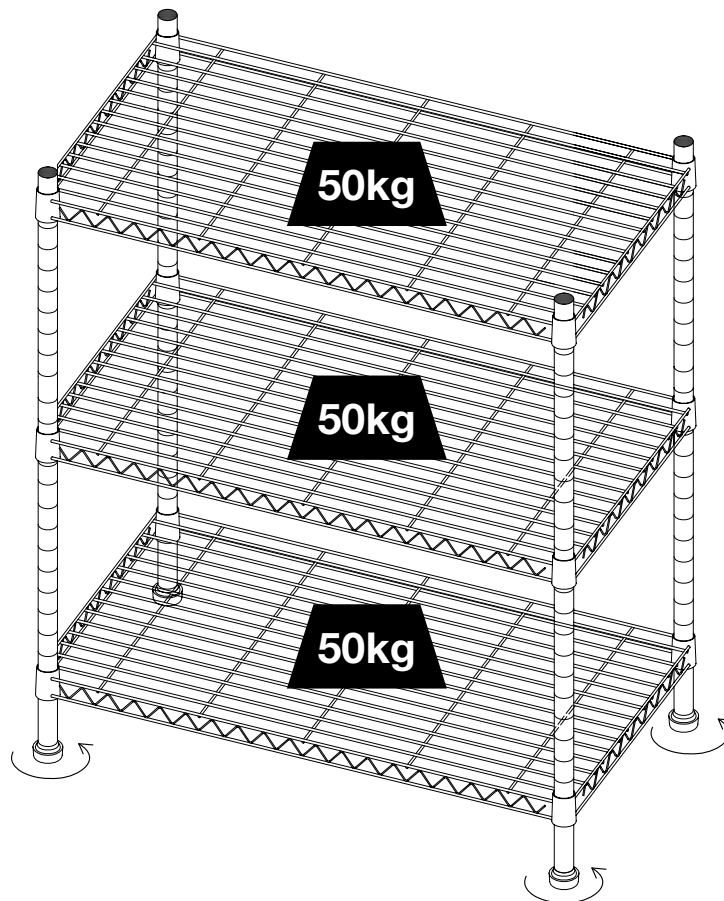

**Max Weight
50kg per shelf**

Your racking is ready for use.